

Troubleshooting/How it works

We tried to keep the Flyleds kit as simple to build as possible. Hopefully you had fun building the kit!

We have seen a common range of problems come to us via email, so hopefully this document will help you out if you are in the head scratching phase of the installation.

First, some quick gotchas

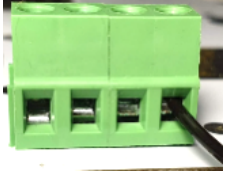

*The green terminal blocks used on the wing boards have wire cages that pull *upwards* to clamp the wire. It is possible to get the wire *under* the clamp rather than *in* the clamp. Unscrew the terminal fully, insert the wire, screw the terminal tight in the regular clockwise righty-tighty direction to grip the wire.

* Check that the pins in the D15 connector are still seated correctly and that they haven't retreated into the plug body.



* Power and ground issues.

We have had a couple of installers come unstuck with testing with an undercharged battery, a low capacity power supply, or a poor power connection somewhere, particularly with temporary setups. In all your tests your system (busbar) voltage should remain fairly steady at around 12.5 volts or so. If you measure the voltage and it fluctuates as the lights flash or as you add more load, find out why! [You can't power your whole plane on 10ft of 20 AWG connecting to the battery sitting on the hangar floor!] If you are testing everything on The Works kit you will have 10 amps or more current being drawn. If you measure 12 volts at your power source but you only have 9 volts (for example) at your power distribution point or out at a device, this will quickly highlight that you have an issue to find, such as a poor connection, a bad crimp, or a too small gauge wire supplying power.

* You *may* test power to the controller board in the aircraft without the wing or tail lights attached.

* If you have the wiring harness in place go to the cut ends of the wing and tail light cables and open up and spread the wires out from under the cable shield to ensure that there are no short circuits before powering up.

Multimeters 101

A digital multimeter is your friend here. If you do not have a multimeter at this point, how did you ever make it this far in life?! Head online or out to your nearest auto parts or electronics store and buy one! \$30 or 40 will buy you a highly capable tool. The \$6 Harbor Freight special does not meet that description...

Two things it must have: "**Auto Power Off**", and most importantly an **audible beeper** function. If it does not have the auto power off feature, it's almost guaranteed that you left it turned on the last time you put it away and it now has a dead battery.

Besides measuring voltage you will find the beeper setting to be the most useful feature to have on your meter.

Set your meter to the beeper mode, which will look something like the examples shown here:

On some meters you may also need to press Select/Mode/Range or something similar to enable the beeper.

* When the red and black test leads are not touching the display will show "1" or "OL" or something similar.

* When you touch the test leads together the meter should beep at you, and the display will also indicate 000 or something close to it.

The beep is indicating you have *continuity*, or something close to zero ohms. Use the beeper mode to check that you have a good connection from one thing to another, such as wires through a connector, or as we will later use, to check if something is connected to the airframe, aka Ground.

In the absence of a beeper mode your multimeter will also have a 200Ω range. It will also show similar readings as described above and help you in the same way.

Note that a continuity test is only useful on de-energised circuits, or if you are looking for a ground connection for example.

Testing a wire for continuity from end to end with 12 volts present on it will lead to unexpected results.

Test for the presence of 12 volts at either end of the wire (or on either side of that plug) instead!

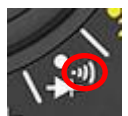
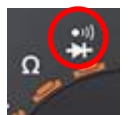
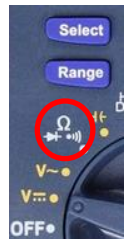

Position lights

The Position/Navigation lights circuit is about as simple as it gets. The controller board plays no part in operating the wingtip position lights, but it is used to energise the tail light.

- (1): 12 volt power is fed from your switch into pin 5, Position+.
- (2): Tracks on the circuit board then connect that +12 volts out to the left and right wings on pin 4 and 13, and for the tail light+ on pin 15 via a diode.

The position light circuits (**only!**, not the strobes...) may be grounded either at the controller board via the cable shield (3) or another wire, **or** locally at the wingtip as shown at (4).

Choose one method for both wings!

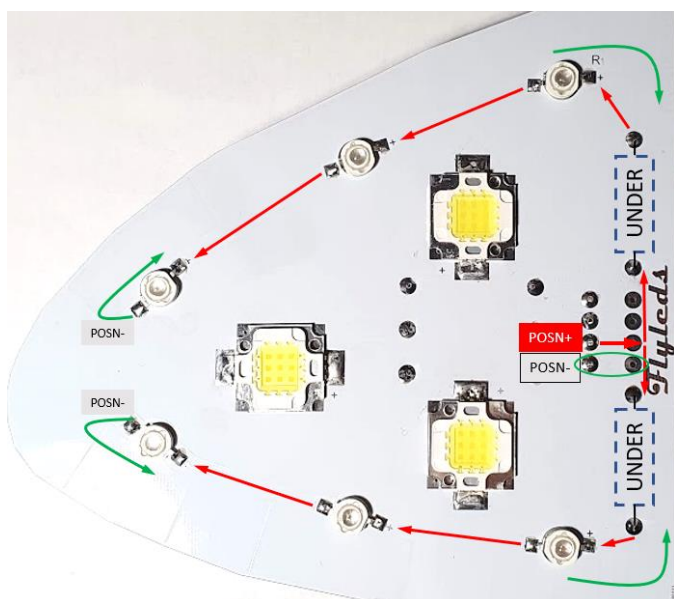
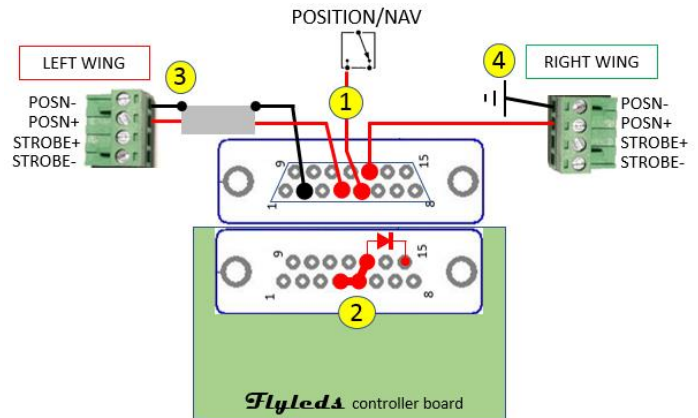

On the wing boards the position LEDs are wired in series in a group of three LEDs, one group along the top of the board and one along the bottom. If one LED is installed backwards all three LEDs in that group won't light up.

Each group of three LEDs is fed by one of the two vertical current limiting resistors, 22 ohms for the left hand red boards and 12 ohms for the right side green boards.

Power comes in on the POSN+ terminal on the green terminal block, goes through the upper and/or lower resistor, then through the three LEDs, as per the red arrows shown here. The third LEDs at the pointy end of the board then connect back to the POSN- terminal via the copper areas around the outside edges of the board, as per the green arrows.

(The keen eyed will observe that this only happens on the 'green' side of the circuit board. On the left hand side red LED boards, the return

current goes through a 'via' hole under the LED leg that connects between the pads on either side of the board.)

The circuit layout concept is similar on The Works spotlight boards.

NOTE: If you attempt to 'test' individual position LEDs with an external power source or even your 9 volt battery, the LEDs will take all the current they can get until they destroy themselves, all in under a millisecond... **don't do this!** Instead use the diode check function on your meter, as already detailed in the assembly instructions for the wing boards.

No position lights:

- * With the power turned off, apply your 9 volt battery across the POSN+ and POSN- terminals, just as you did when you tested your newly built boards. Try again with the harness unplugged just in case you have a wiring issue shorting things out.
- * With the Position light switch on, use your meter to check for +12 volts between POSN+ and POSN-, and then between POSN+ and the airframe (ground). If the first test fails but the second reads 12 volts you have a ground connection issue.
- * Did you drill a mounting hole through one of the circuit traces between the LEDs, such as where the red arrows are (above)?

One string of three position lights has stopped working:

- * Check your soldering! Reheat each component leg again, as well as the relevant resistor feeding power to that string.
- * With power turned on you can measure the voltage across each LED. Normally they should all be around 2.1 volts (red) or 2.5 volts (green) or similar. If one is going faulty it will measure 6 volts or more, and it steals the current from the other two LEDs.
- * You could check for continuity between the LEDs, as well as proving that the green arrows above really are true.
- * Check the individual LEDs are still work using the diode check function on your multimeter (only!).
- * Both groups of three LEDs on *one board* not working? Check the screw terminals for the wiring running between the boards.

Strobes

The important concept to understand with the Flyleds kits is that the strobe LEDs are flashed/turned on when the controller board intermittently switches their *negative or minus* lead to ground.

Note the wiring diagrams and the terminals on the wingtip boards; there is no “Strobe Ground” connection, only **STROBE+** (plus) and **STROBE-** (minus) terminals. There is a difference!

(1): When the Strobe switch is turned on, power is applied to pin 10 of the controller board.

(2): The circuit board traces then feed 12 volts directly out to pin 11 and 12 for the left and right STROBE+ wires (orange), and for the tail light+ on pin 15 via another diode.

(3): Power goes through the individual strobe LEDs on the wings with their individual resistors (see below).

The STROBE- wire from the wings (white) connects back to the relevant Left/Right/Tail STROBE- pins on the controller board (pins 3, 6, 8).

(4): The CPU on the controller board turns on the small switching MOSFET transistors in sequence. This intermittently connects the STROBE- wire to ground which turns the LEDs on (flashes or strobes them).

Only one transistor is shown here, but there is also one for the left wing and one for the tail.

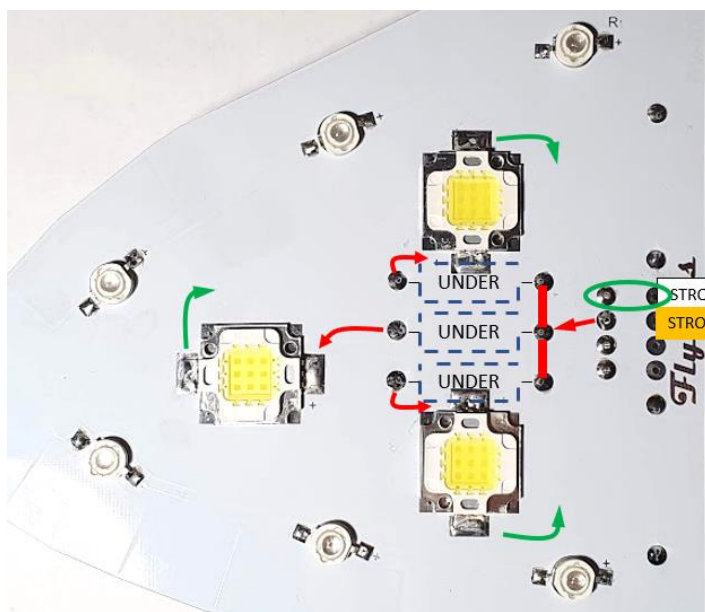
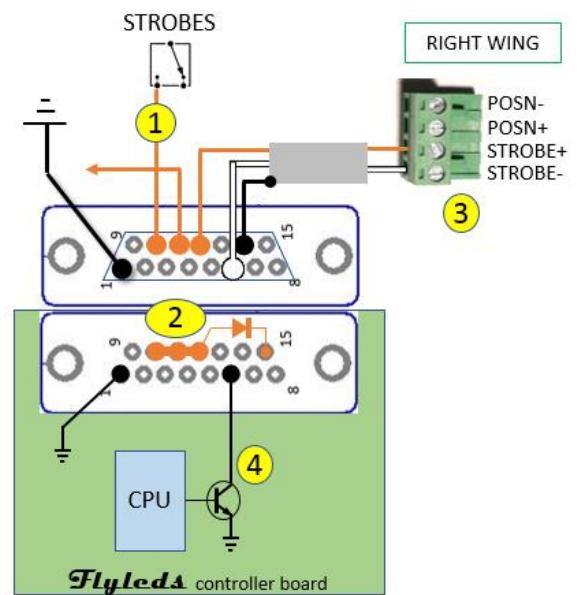

At the wings, strobe 12 volt power comes in on the STRB+ terminal on the green terminal block.

The three 3.9 ohm current limiting resistors then feed power to the three individual strobe LEDs (red lines). The LED negatives then connect back to the STRB- terminal via the bulk copper area in the middle of the circuit board (green lines).

The individual strobe LEDs *may* be tested directly using a 9 volt battery (**only!**), as the battery itself can only deliver a small amount of current. These rarely fail. The circuit layout concept is similar on The Works spotlight boards.

RV-9, “Batwing” and Team Rocket Works boards have three small Cree LEDs wired in series like the position LEDs. They are fed by two parallel 2.7 ohm resistors. Please do NOT test these LEDs individually.

One LED not working? Try reflowing the solder joints for that LED and for the resistor that feeds it.

Strobes permanently on:

As detailed above, the strobe LEDs operate when the transistors on the controller board connects the STROBE- line to ground. A few customers have chosen to connect the STROBE- line to ground, which results in the strobe LEDs being ‘stuck’ on.

A stray strand of the shield wire touching the STROBE- wire or pins at either end of the cable will have the same effect. Check your harness plugs closely. If you decided to connect the STROBE- wires to your common ground, connect them to the controller board pins as per the instructions instead!

Do you have any extra terminal blocks or connections in the wire run to the wings? Double check these.

Dim or No strobes:

Check for continuous +12 volts on the STROBE+ terminal with your black meter probe on the airframe as your ground point. If 12 volts is present, you can create a temporary ground by touching a scrap of wire between the airframe (ground) and the STROBE- terminal. If the strobes now operate or are much brighter then that points to an issue with the STROBE- line.

The beep test

We highlighted the use of the continuity tester on page 1 because it is extremely useful in diagnosing strobe issues.

If the strobes are 'stuck on' on one wing you need to determine if it's a controller board issue (rare) or a wiring issue (often!).

* Turn on red switch 4 to enable the longer flash pattern. This might help with some meters that are slow to beep.

* At the controller board connect the black meter lead to ground, such as a local airframe ground, pin 1, or the metal body of the D15 connector. Touch the red meter lead to the wire terminal going in to pin 3 or 6. You should hear short beeps in time with the on-board LEDs flashing. This is the switching FETs connecting your meter leads together via ground. Perfect!

* If you hear a permanent beep, unplug the harness and test again between the airframe ground and that pin on the harness. If the meter still beeps continuously then you have a short to ground on that wire somewhere.

* You can also power up the controller board with a 9 volt battery and some scraps of wire.

Touch the black meter lead to the body of the DB15 socket and the red probe to either pin 3 or 6, or the metal tab on the body of the switching MOSFET transistors. Short beeps should be heard here!



* You can also perform the Beep Test out at the wing boards between STROBE- and airframe ground to prove your wiring.

Tail Light.

The Flyleds Kit version tail light has three Cree LEDs in series and no current limiting resistor. The tail light relies on the large power resistor(s) on the controller board for current limiting. Connecting the light directly to 12 volts (even for testing) will destroy it!

As per the wing strobes, the tail light is flashed/turned on/strobed when the transistors on the controller board switch the tail light's negative lead to ground.

The early "The Original" kit controller board has two large power resistors, as shown below. The board connects the tail light to ground via the 22 ohm resistor for position light mode, effectively limiting the power and brightness to around 10%. It intermittently connects the tail light to ground via the 1.5 ohm resistor for each strobe flash, giving the tail light 100% power.

The Works kit and The Essentials kit controller board has one large 1.5 ohm resistor in the TAIL+ line (pin 15) to the tail light. A transistor connects the tail light black wire to ground rapidly for 1 millisecond out of every 10 for Position light mode, which gives it 10% power, or permanently to ground for each strobe flash at 100% power. (Google 'PWM' if you're interested!)

Tail light permanently on, and bright and hot...

* Did you connect the tail light's black wire to a local ground? (Don't.)

* Did you connect the cable shield to the tail light's black wire? (Don't!)

* Check the pin connections at the controller board end, ensuring that the two tail light wires are in pin 15 and 8, and the shield is connected to pin 7. A few customers have swapped the wires between pins 7 & 8.

* Is the shield wire going into pin 7 fully insulated? Any stray strands touching pin 8?

* For The Original kit, are the 22 and 1.5 ohm resistors in their correct locations on the PCB? (see below)

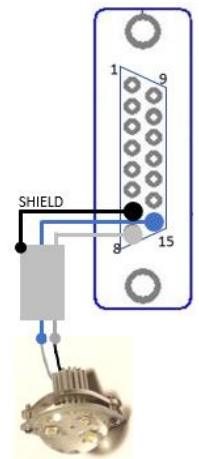

No tail light

You may use a square 9 volt battery (the type used in a household smoke alarm) to test your tail light and the wiring to it, as this type of battery can only deliver a small current and it won't damage the tail light.

Obviously it won't be as bright as if it was supplied with 12 volts and full current, but it should be a good indicator of the health of the tail light and the wiring to it.

* Check for +12 volts on pin 15 at the controller board, and between the tail light's white wire and airframe ground. A normally working tail light will show about 8.5 volts between Tail+ and Tail-.

Beep test

For The Original kit, you can confirm that the switching MOSFETs are still happy and healthy by performing the Beep Test described above with your black meter lead connected to ground, and the red lead touching the resistor leg at point P for Position light mode and point S for each Strobe flash.

Any other issues? Please email Paul for further advice.

